

## Pegasus Winged Rudders

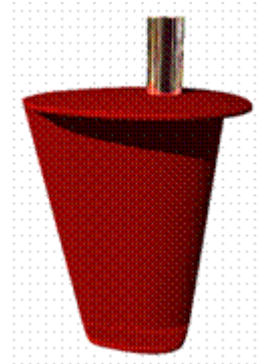
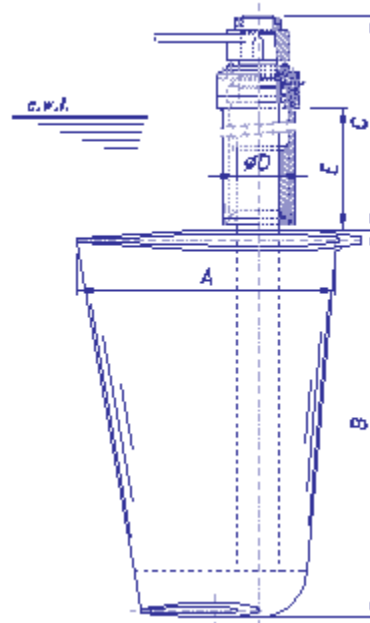

Poseidon Pegasus Winged Rudder Size Table – measurements in mm					
Type	A	B	C	D	E
70	350	525	400	70	225
80	450	675	500	80	300
90	550	825	625	90	400
100	650	975	750	100	500
120	750	1125	825	120	575
140	850	1275	950	140	650

Poseidon Pegasus Winged Rudders are specially designed to improve performance at higher speeds. Reinforced polyester shell in combination with welded metal cage and shaft are built to meet rules of Lloyds and ABS. Pegasus Winged Rudders offer the following advantages:

- Weight Savings and improved vessel trim at speed.
- Increased steering control and stability at high speeds.
- Dramatic Noise and Vibration reduction through reduced cavitations and turbulence.
- For use in new or existing construction
- Supplied with either GRP, steel or aluminum rudder tube housing to suit any project.

©2009 Donovan Marine, Inc. All Rights Reserved.

*Product specifications and other information have either been provided by our Vendors or collected from publicly available sources. While Donovan Marine, Inc. makes every effort to ensure that the information contained in this document is accurate, we can make no representations or warranties as to the accuracy or reliability of any information provided. Donovan Marine, Inc. makes no warranties or representations whatsoever with regard to any product provided or offered by any Vendor, and you acknowledge that any reliance on representations and warranties provided by any Vendor shall be at your own risk.*

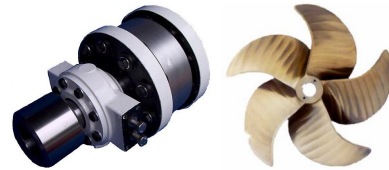

## Poseidon *Pegasus* - STANDARD Rudder Seal and Tube Assemblies

**Pegasus- STANDARD** - Equipped with a bronze top bearing, lip seals and O-Ring seal at bottom and non-metallic lower bearing. Tiller can be fabricated to meet any steering system. Can be used on GRP Pegasus Wing Rudders or any fabricated bronze, steel, or stainless rudder.

Type	L.o.	D.o.	D.s.
Std.	Stock Ht.	Tube Dia	Stock Dia
70	400	120	70
80	500	145	80
90	625	155	90
100	750	165	100
120	825	180	120
140	950	200	140
160	1050	240	160
200	1300	260	200

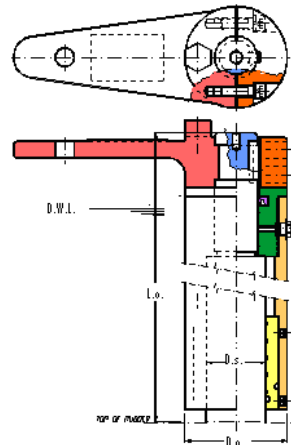

**Pegasus - DELUXE** - Equipped with spherical roller bearings, lip seals at top and bottom and a non-metallic lower bearing. Tiller can be fabricated to meet any steering system. Can be used on GRP Pegasus Wing Rudders or any fabricated bronze, steel, or stainless rudder.

Type	L.o.	D.o.	D.s.
Std.	Stock Ht.	Tube Dia	Stock Dia
70	400	150	70
80	500	165	80
90	625	180	90
100	750	200	100
120	825	225	120
140	950	245	140
160	1050	270	160
200	1300	290	200

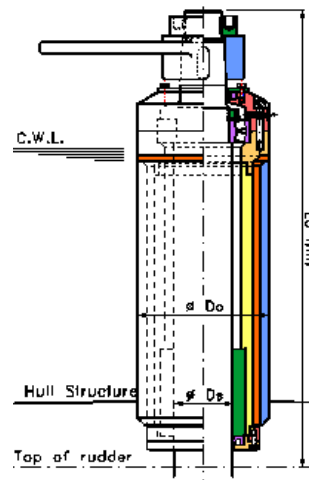

©2009 Donovan Marine, Inc. All Rights Reserved.

*Product specifications and other information have either been provided by our Vendors or collected from publicly available sources. While Donovan Marine, Inc. makes every effort to ensure that the information contained in this document is accurate, we can make no representations or warranties as to the accuracy or reliability of any information provided. Donovan Marine, Inc. makes no warranties or representations whatsoever with regard to any product provided or offered by any Vendor, and you acknowledge that any reliance on representations and warranties provided by any Vendor shall be at your own risk.*